

SAFETY, OPERATION MANUAL w/PARTS LIST

P4710-DAF & MAVP47-BAF HAZARDOUS WASTE DRY VACUUM CLEANER



READ & FOLLOW ALL INSTRUCTIONS, WARNINGS & CAUTIONS BEFORE USING THIS VACUUM

This vacuum will afford you many years of trouble-free operating satisfaction, provided it is given proper care. All parts have passed rigid quality control standards prior to their being assembled to produce the finished product. Prior to packaging, your vacuum was again inspected for assurance of flawless assembly.

This vacuum is protectively packed to prevent damage in shipment. We recommend that upon delivery, unpack the unit and inspect it for any possible damage. Only a visual examination will reveal damage that may have occurred.

If damage is discovered, immediately notify the transportation company that delivered your vacuum. As a shipper, we are unable to

report any claim for damage. You must originate any claim within 5 days.

This manual is for your protection and information. **PLEASE READ CAREFULLY** since failure to follow precautions could result in discomfort or injury. Read this manual completely before operating this vacuum. It is important to follow the instructions in the manual to prevent the possibility of injury or damage to the user and/or machine.

Treat your vacuum cleaner as you would any other high grade precision made product. Dropping, unreasonable bumping across thresholds and other misuses may result in a damaged unit that will not be covered by warranty.

PLEASE READ CAREFULLY BEFORE OPERATION

SAVE THESE INSTRUCTIONS

P4710-DAF

ELECTRIC

IMPORTANT SAFETY

INSTRUCTIONS



WARNING:

*To Reduce the Risk of Fire, Electric Shock or Injury:
Electric shock could occur if used on wet surfaces.
DO NOT expose to rain. Store indoors.*

When using this vacuum basic precautions should always be followed, including the following:

- 1) **DO NOT** leave the vacuum when plugged in. Unplug from the outlet when not in use and before servicing.
- 2) To avoid electric shock, **DO NOT** expose to rain. Store indoors. **DO NOT** use on wet surfaces.
- 3) This is **NOT** a toy. Close attention is necessary when used around or near children.
- 4) Use only as described in this safety manual. Use only manufacturer's recommended attachments and accessories.
- 5) **DO NOT** use this vacuum with damaged cord or plug. If the vacuum is not working as it should, because it has been dropped, damaged, left outdoors or dropped into water, contact an authorized service center or factory.
- 6) **DO NOT** unplug the vacuum by pulling on the cord. To unplug, grasp the plug, not the cord.
- 7) **DO NOT** handle the vacuum plug

with wet hands.

8) **DO NOT** pull or carry by the cord, use cord as a handle, close a door on cord or pull cord around sharp edges and corners. **DO NOT** run vacuum over cord. Keep cord away from heated surfaces.

9) Keep hair, loose clothing, fingers, and all parts of body away from openings and moving parts.

10) Use extra care when cleaning on stairs.

11) **DO NOT** put any objects into openings. **DO NOT** use with any opening blocked; keep free of dust, lint, hair and anything that may reduce air flow.

12) **DO NOT** pick up anything that is burning or smoking, such as cigarettes, matches, or hot ashes.

13) **DO NOT** use without 2-ply disposable paper filter bag, 2-ply intermediate filter and HEPA filter in place.

14) Turn **OFF** all controls before unplug-

ging

15) **DO NOT** use the vacuum to pick up flammable or combustible liquids such as gasoline or use in areas where they may be present.

16) **DO NOT** use where anesthetics or oxygen is used.

17) **DO NOT** use an extension cord unless absolutely necessary. If an extension cord is used, then wire size must be #14 or larger and should not exceed 50 feet in length. The extension cord must be a three-wire type to insure **GROUNDING** protection.

18) Replace damaged or worn parts immediately with genuine original equipment parts to maintain safety and to protect your limited warranty.

This vacuum must be connected to a properly grounded outlet only. (See grounded instructions). When not in use the power cord should be wrapped around the motor head for storage.

MAVP47-DAF

AIR-OPERATED

IMPORTANT

SAFETY

INSTRUCTIONS

1) The air supply should not exceed 150 PSI.

2) Use compressed a air line rated for 200 PSI or better.

3) Water separator must be used on compressed air line.

4) **DO NOT** use to pickup flammable and/or combustible material.

5) When the vacuum is **ON**, never allow fingers, hair or loose clothing to come near intake, suction ports or nozzle.

6) Air control valve must be **OFF** before connecting to compressed air line, than open valve slowly making sure not exceed the 150 PSI rated pressure.

7) **DO NOT** use without paper filter bag, intermediate filter and HEPA filter in place.

8) Replace damaged or worn parts immediately with genuine original equipment parts to maintain safety and to protect your limited warranty.

CAUTION:

The air supply **MUST** be turned **OFF** when the vacuum action stops.



SAVE THESE INSTRUCTIONS



⚠ DANGER:

Improper use of the grounding plug can result in a risk of electric shock.

GROUNDING INSTRUCTIONS

Electrical equipment must be grounded. If it should malfunction or breakdown, grounding provides a path of least resistance for electrical current to reduce the risk of electric shock. This vacuum is equipped with a cord having an equipment-grounding conductor and grounding plug. The plug must be inserted into an appropriate outlet that is properly installed and grounded in accordance with all local codes and ordinances.

If repair or replacement of the cord or plug is necessary, **DO NOT** connect grounded wire to either flat blade terminal. The wire with insulation having an outer surface that is green with or without yellow stripes is the grounding wire.

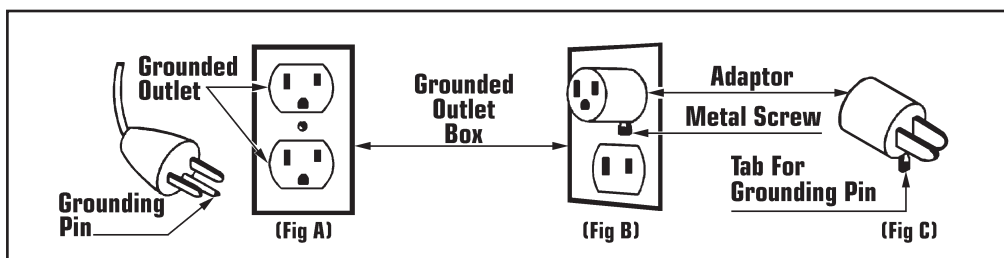

GROUNDING METHODS

This electric equipment is for use on a nominal 120 volt circuit, and has a grounded plug that looks like the plug illustrated in (Fig A). A temporary adaptor that looks like the adaptor illustrated in (Fig B & C) may be used to connect this plug to a 2-pole receptacle as shown in (Fig B) if a properly grounded outlet is not available. The temporary adaptor should be used

only until a properly grounded outlet (Fig A) can be installed by a qualified electrician. The green color rigid ear, lug or the like extending from the adaptor must be connected to a permanent ground such as a properly grounded outlet box cover. Whenever the adaptor is used, it must be held in place by a metal screw. (Fig C).

⚠ WARNING:

Improper connection of the equipment-grounding conductor can result in a risk of electric shock. Check with a qualified electrician or service person if you are in doubt as to whether the outlet is properly grounded. **DO NOT** modify the plug provided with the equipment. If it will not fit the outlet, have a proper outlet installed by a qualified electrician.

Note: In Canada, the use of a temporary adaptor is not permitted by the Canadian Electrical Code.



This vacuum has been specifically designed to clean up hazardous dust. Special filters reduce the incidence of airborne dust that would be created by other methods of cleaning.

During the removal of hazardous dust, **DO NOT** sweep, scoop, shovel or in any manner handle other than by vacuuming.

DO NOT at any time attempt to remove, substitute, bypass or by any other means change the filters in the vacuum.

Use only manufacturer's approved vacuum filters and filters bags.

Before attempting to use or before cleaning with this vacuum, be sure that you fully understand the instructions for setting up or cleaning/changing filters.

Any health hazards associated with use of this vacuum in conjunction with the removal of hazardous material has not been investigated by Underwriters Laboratories, Inc.

INTENDED USE OF THE VACUUM

UNPACKING & CASTER INSTALLATION

Remove the vacuum, hose and wand from the shipping carton. Disengage the clamps on the tank and carefully remove the motor head, filter assembly, tools and casters packed inside the vacuum tank. To install the casters, turn the tank upside down and press casters into the plastic sockets until bottom of stem fits flush against the plastic sockets.

Reinstall the filters and reassemble vacuum following the instructions below.

DO NOT use this unit until the owner's manual has been read. Improper use could cause damage to the vacuum or the special filters employed.



CAUTION:

To insure a snug fit, make sure that the area around the lid and top edge of the vinyl sealing gasket is free of dirt and other foreign matter.

NEVER operate the vacuum cleaner without a HEPA filter and 2-ply disposable paper bag in place and NEVER, NEVER without the intermediate filter in position. Motor damage, loss of operating efficiency and re-circulation of hazardous material into the work area will take place.

INSTALLATION OF FILTERS

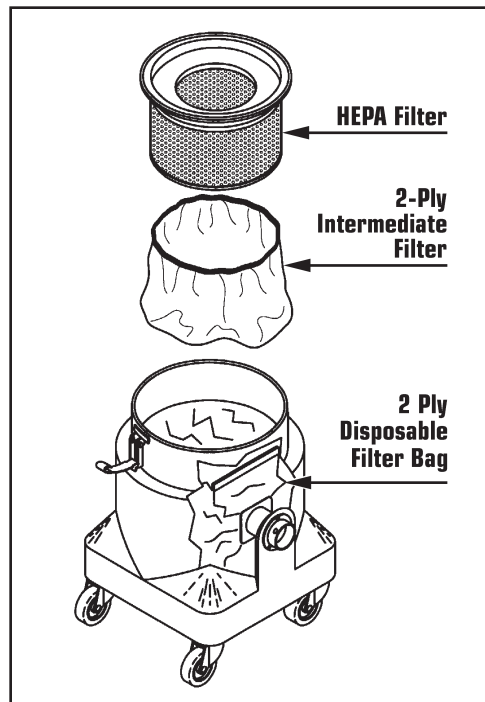

The 2-ply intermediate filter is a very fine non-woven filter that extends the life of the expensive High-Efficiency Particulate Air (HEPA) filter.

1) Disengage clamps that hold motor head to the tank. Carefully set aside.

2) Remove HEPA filter and 2-ply intermediate filter. Set aside.

3) Install a new disposable 2-ply paper filter bag by taking hold of the free ends of cardboard attached to the paper bag. Pull the cardboard forward over inlet fitting so that the cardboard is as close to the tank wall as possible.

4) Place the 2-ply intermediate filter in position on top of the tank. Fold the edge over the outside of tank, overlapping approximately one inch.

5) Insert the HEPA filter, being careful not to move the 2-ply intermediate filter. The filter's sealing gasket must sit evenly on the tank rim so an air tight seal will be obtained.

6) Replace motor head assembly on top of HEPA filter seated in the top of the tank.

This hazardous waste vacuum has special filters installed. The 2-ply disposable paper filter contains the bulk of all debris and protects remaining filters from excess dirt.



CAUTION:

Hazardous materials must be disposed of properly. NEVER throw contaminated debris in your usual trash receptacle. Place debris in a OSHA approved poly bag or container marked with HAZARDOUS MATERIAL warning and dispose in accordance with your local Hazardous Waste Regulations.

WHEN TO CHANGE FILTERS



CAUTION:

Always unplug the vacuum from the power source before changing filters.

2-Ply Disposable Paper Filter Bags



When the 2-ply disposable paper filter bag is $\frac{3}{4}$ full, it **MUST** be replaced. Excessive over filling of this bag makes it difficult to remove from the vacuum tank and can result in breakage and spills.

2-Ply Intermediate Filter



The 2-ply intermediate filter should be replaced with every fifth change of paper bag and whenever there is damage or a visible collection of debris on the outside of the filter.

HEPA Filter

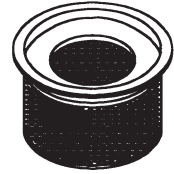

Replace the HEPA filter when loss of vacuum continues to occur after you have checked for an obstructions in the hose or wand. Also, install a new 2-ply disposable paper bag and 2-ply intermediate filter.

PROCEDURES FOR REMOVING CONTAMINATED FILTERS & CLEANING A CONTAMINATED TANK

2-Ply Disposable Paper Filter Bag:

- 1) Carefully and slowly remove the motor head, HEPA filter and 2-ply intermediate filter. Set aside.
- 2) Using a damp cloth, wipe down all exposed surfaces inside of tank and set cloth down. **DO NOT** discard cloth.
- 3) Lay the vacuum tank on its side with inlet on top, carefully and slowly push cardboard off air inlet tube.
- 4) Remove paper backing from sealing flap located over cardboard collar. Press sealing flap firmly over the opening to prevent spill back of recovered materials.
- 5) Slowly and very carefully lift the 2-ply disposable paper filter bag out of tank, using care not to puncture the bag with inlet.

- 6) Wipe off any surface that has not been previously wiped with the damp cloth including the entire inside of tank.
- 7) Place the 2-ply disposable paper filter bag and damp cloth in a OSHA approved poly bag, dispose of it in accordance with the local Hazardous Waste Regulations.

2-Ply Intermediate Filter:

- 1) Remove motor head. Using a damp cloth wipe down all exposed surfaces on underside and carefully set aside. Put wiping cloth down, **DO NOT** discard.
- 2) Remove the HEPA filter cautiously as not to damage or puncture paper media used in the filter. Set aside.
- 3) Remove 2-ply intermediate filter and dispose of it along with the wiping cloth in a OSHA approved poly bag.

- 4) Install a new 2-ply intermediate filter, insert HEPA filter, replace motor head and engage clamps.

HEPA Filter:

- 1) Remove motor head. Using a damp cloth wipe down all exposed surfaces on the underside and carefully set aside. Put wiping cloth down, **DO NOT** discard.
- 2) Remove HEPA filter cautiously and dispose of it along with the 2-ply intermediate filter, 2-ply disposable filter bag and wiping cloth in a OSHA approved poly bag.
- 3) Install a new 2-ply disposable filter bag, 2-ply intermediate filter and, insert a new HEPA filter, replace motor head and engage holddown clamps.

(See page 4 for Filter Installation Instructions)



CAUTION:

For the benefit of your health, always wear gloves and an OSHA approved face mask for use with asbestos any time you are operating or cleaning this vacuum cleaner.

P4710-DAF ELECTRIC MOTOR HEAD REPLACEMENT PARTS LIST

| Ref No | Part Description | Qty | Part No |
|--------|--------------------------|-----|---------|
| | Complete Motor Head Assy | 1 | 354805 |
| 1 | #8 X 1" Screw | 4 | 394270 |
| 2 | Strain Relief | 1 | 443379 |
| 3 | 50 Ft Yellow Line Cord | 1 | 318647 |
| 4 | #8-32 Nylon Hex Nut | 6 | 385158 |
| 5 | Lower Dome Assembly | 1 | 394610 |
| 6 | Silencing Liner | 1 | 302368 |
| 7 | Purse Lock | 1 | 365491 |
| 8 | Upper Motor Gasket | 1 | 378607 |
| 9 | 1 HP By-Pass Motor | 1 | 337757 |
| 10 | Orange Wire Nut | 3 | 398985 |
| 11 | 12" Cover | 1 | 417432 |
| 12 | #8-32 X .38 Screw | 6 | 415758 |
| 13 | Circle Gasket | 1 | 416290 |
| 14 | Motor Screen | 1 | 394432 |
| 15 | Lower Motor Gasket | 1 | 394300 |
| 16 | #12 Int Tooth Lockwasher | 1 | 364037 |
| 17 | #10 Ground Screw | 1 | 393258 |
| 18 | Spacer | 4 | 361054 |
| 19 | Rocker Switch | 1 | 393754A |
| 20 | #10 Hex Screw | 4 | 368385 |
| 21 | Silencing Disc | 1 | 396028 |
| 22 | Upper Dome Assembly | 1 | 394602 |

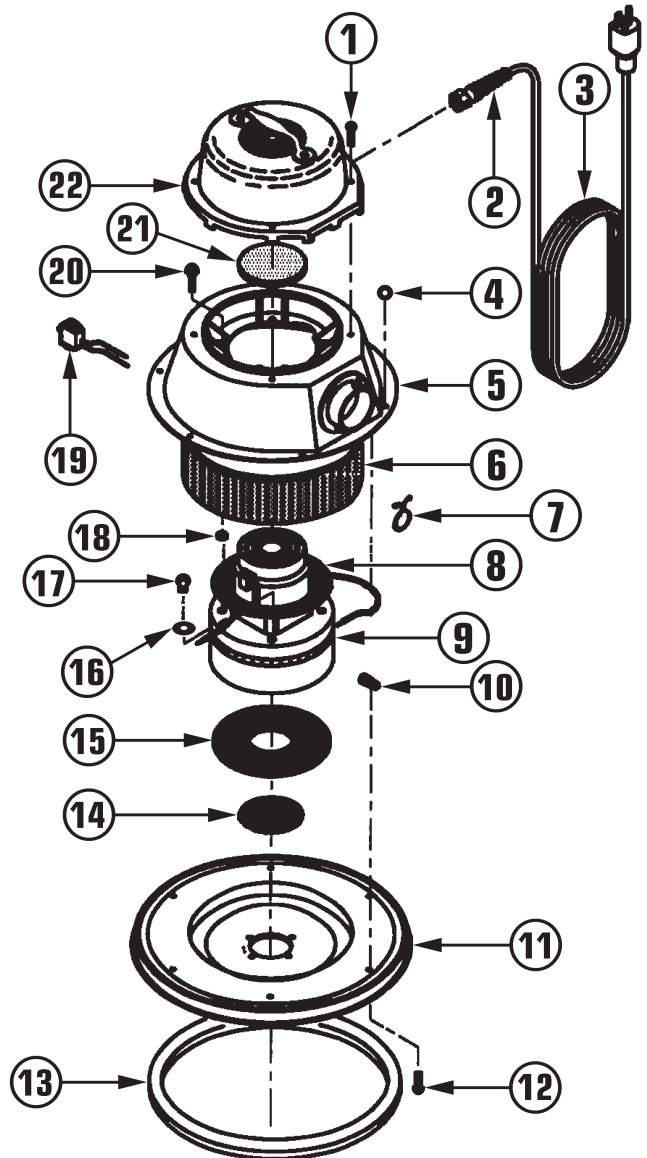

P47 TANK ASSEMBLY REPLACEMENT PARTS LIST

| Ref No | Part Description | Qty | Part No |
|--------|------------------------|-----|---------|
| 1 | Pop Rivet | 9 | 374733 |
| 2 | Holdown Clamp | 3 | 358312 |
| 3 | Steel Washer | 9 | 303909 |
| 4 | Plastic Caster Socket | 4 | 371750 |
| 5 | 2 1/2" Swivel Caster | 4 | 307408 |
| 6 | Inlet Fitting | 1 | 325406 |
| 7 | Complete Tank Assembly | 1 | 371432 |

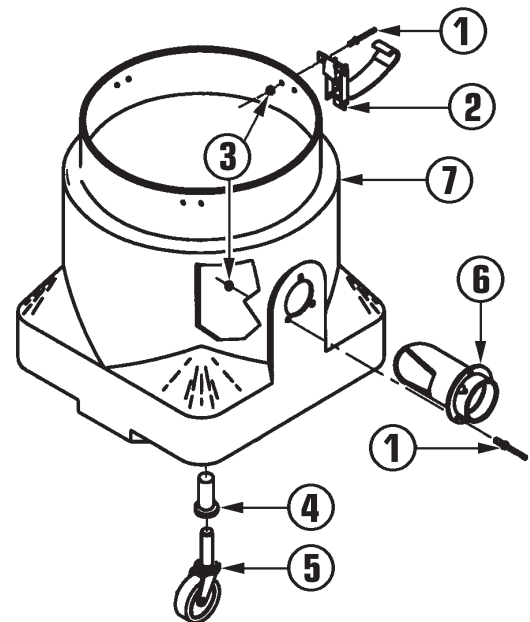

MAVP74-BAF COMPRESSED-AIR MOTOR HEAD REPLACEMENT PARTS LIST

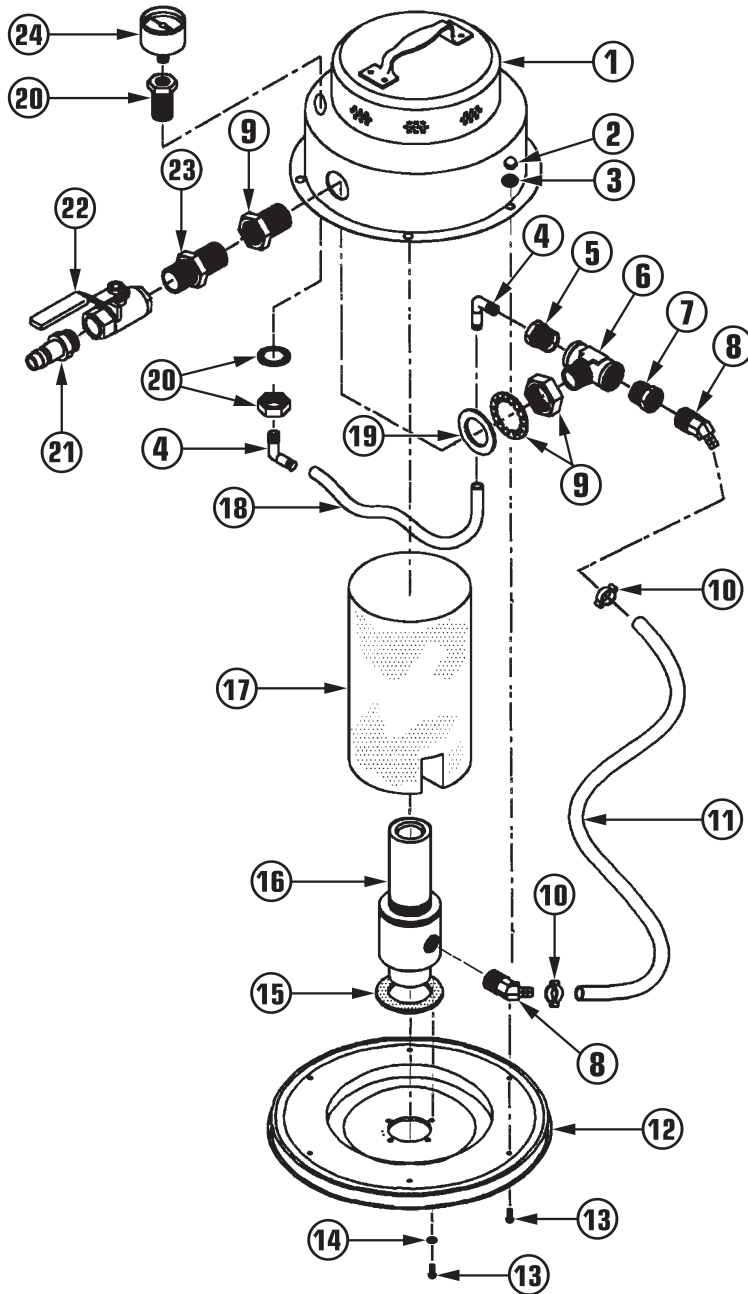

| Ref No | Part Description | Qty | Part No |
|--------|-----------------------------|-----|---------|
| | 12" Air-Operated Head Assy | 1 | 368563 |
| 1 | Dome Assembly | 1 | 304077 |
| 2 | #10-24 Acorn Nut | 6 | 359807 |
| 3 | #10-24 Hex Nut w/Lockwasher | 6 | 331201 |
| 4 | 1/8" NPT Elbow Fitting | 2 | 304395 |
| 5 | 1/2" to 1/8" Reducer | 1 | 304298 |
| 6 | 1/2" Tee Fitting | 1 | 304379 |
| 7 | 1/2" to 3/8" Reducer | 1 | 359947 |
| 8 | 1/2" Brass Nipple Fitting | 2 | 304697 |
| 9 | 1/2" NPT Bulk Head Assembly | 1 | 304115 |
| 10 | 5/8" Hose Clamp | 2 | 304948 |
| 11 | 3/8" High Pressure Hose | 1 | 304964 |
| 12 | 12" Cover Assembly | 1 | 417432 |
| 13 | #10-24 X 1/2" Screw | 10 | 341622 |
| 14 | #10 Lockwasher | 4 | 380725 |
| 15 | Flat Gasket | 1 | 416460 |
| 16 | Venturi | 2 | 304506 |
| 17 | Muffler | 1 | 306096 |
| 18 | 1/4" OD Tubing | 1 | 304492 |
| 19 | SS Reinforcing Ring | 1 | 374865 |
| 20 | 1/8" NPT Bulk Head Assembly | 1 | 304093 |
| 22 | Ball Valve | 1 | 304468 |
| 21 | 1/2" QDC Male Fitting | 1 | 304484 |
| 23 | 1/2" Brass Nipple Fitting | 1 | 351679 |
| 24 | O-200 Pressure Gauge | 1 | 304131 |

FILTER REPLACEMENT PARTS LIST

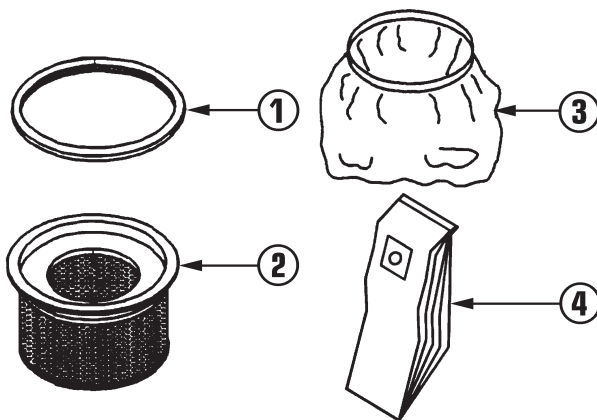

| Ref No | Part Description | Part No |
|--------|----------------------------------|---------|
| 1 | HEPA Filter Gasket | 302392 |
| 2 | 12" HEPA Filter | 306061 |
| 3 | 2-Ply Intermediate Filter (2/Pk) | 347515 |
| 4 | 2-Ply Paper Filter Bag (5/Pk) | 411973 |

TROUBLE SHOOTING GUIDE

PROBLEM: Loss of Vacuum.

Possible Cause:

1. Full paper 2-ply disposable filter bag.
2. Dry filter assembly clogged.
3. Clogged hose or wand.
4. Tank rim damaged.
5. Loose or broken fan.
6. Motor not working.
7. Gasket worn.

Possible Solution:

1. Replace 2-ply disposable paper filter bag.
2. Clean cloth filter.
3. Remove obstruction.
4. Replace tank.
5. Contact manufacturer or service center.
6. Contact manufacturer or service center.
7. Replace gasket.

PROBLEM: Motor is not running.

Possible Cause:

1. Broken switch or motor defective.
2. Power cord defective.
3. Blown fuse or tripped circuit breaker.

Possible Solution:

1. Contact manufacturer or service center.
2. Contact manufacturer or service center.
3. Replace fuse or reset circuit breaker.

PROBLEM: Dust blowing from vac when running.

Possible Cause:

1. Full or torn 2-ply disposable paper filter bag.
2. Paper filter bag not installed properly or off inlet tube.

Possible Solution:

1. Replace 2-ply disposable filter bag.
2. Reinstall or replace 2-ply disposable paper filter.

OPTIONAL TOOL KITS AND ASSEMBLY INSTRUCTIONS



1 1/4" DRY TOOL KIT

10 Ft Hose/Elbow/Connector;
2 Pc Straight Wand; 3-Way Carpet Tool;
Upholstery Tool; Floor & Wall Brush;
9" Crevice Tool; Dusting Brush



1 1/2" Dry Tool Kit Includes

10 Ft Hose/Connector; 2 Pc Steel Wand
14" Floor Brush; 14" Carpet Tool
11" Crevice Tool; 6" Upholstery Tool;

Hose & Swivel Connector

The hose and swivel connector are pre-assembled at the factory. To attach the swivel connector to intake fitting on vacuum tank:

- 1) Line up swivel connector slots with retaining rivets on the intake.
- 2) Insert swivel connector and twist clockwise until rivets reset against slot end.

1 1/4" Tool Kit Assembly

Wand Assembly: Both sections are exactly the same. Slide the tapered end of one section into the slotted end of the other wand section.

Attach Hose: Slide curved elbow on hose into wand end with slots on the side.

Install Tool: Insert tool into the tapered end of the wand.

1 1/2" Tool Kit Assembly

Wand Assembly: Align button lock of upper wand section with the opening for button lock in the lower wand section and push sections together.

Attach Hose: Slide free end of hose into the grooved end of upper wand.

Install Tool: Turn wand nut counterclockwise approximately (4) complete turns. Insert the tool into wand nut and coupling. While holding tool in place, turn nut clockwise until wand nut is fully locked.